



Lamborghini
MACH
VRT T4

210 - 230 - 250





CONTENT



p. **4-5**
**MACH VRT:
LAMBORGHINI STYLE
WITH PURE POWER.**

p. **6-13**
**BOLD PERSONALITY
WITH EYE-CATCHING LOOKS.**

p. **14-17**
**INNOVATION
COMES FROM THE HEART.**





p. 18-21
**EFFICIENCY FOR
WORKING BETTER.**

p. 22-29
**A TRACTOR THAT
GOES THE EXTRA MILE.**

p. 30-31
TECHNICAL DATA







MACH VRT: LAMBORGHINI STYLE WITH PURE POWER.

The Lamborghini Mach VRT is the powerful flagship of the new range from the raging bull: a tractor boasting state of the art technology, comfort and design with engines up to 263 HP and continuously variable transmissions.

Offered as three variants 210-230-250, the Mach VRT sets new standards for reliability, safety and fuel economy, and also cares for the environment, with engines using clean SCR technology.

All of these characteristics contribute to making the Mach VTR the perfect choice for large farms and farming contractors, for large land areas and the most demanding jobs.







BOLD PERSONALITY WITH EYE-CATCHING LOOKS.

Choosing a Lamborghini tractor means working in style. Designed by Giugiaro, the Mach VRT boasts a futuristic, distinctive style, with every detail and technological solution conceived for total comfort and rational functionality.

The new MaxiVision Cab sets new benchmarks for its outstanding visibility and for interior comfort in every detail from the layout of the driver position to the quality of the materials. Ergonomic controls and the work monitor mounted on the A-pillar offer total freedom of movement within the cab, and place all the controls at the fingertips of the driver for unparalleled simplicity.

The combined effect of the sprung cab and axle optimises performance on rough terrain and at high speeds, and drastically reduces the vibration experienced by the driver, for impeccable comfort in all conditions.

Three modes (automatic, manual and PTO) let the driver instantaneously select the right settings for the job in hand, for optimum control in all situations.





Hydraulic power shuttle

The hydraulic reverse shuttle with SmartWheel lets the driver adjust direction modulation response to suit the working conditions.



Multi-function lever

A multi-function controller lets the driver operate the tractor at very low speeds without additional reduction gears and without using the clutch, accelerator or brakes.

The driver can adjust the acceleration range setting from the dial in all driving modes. Information on the acceleration setting is viewable on the iMonitor 2.0.

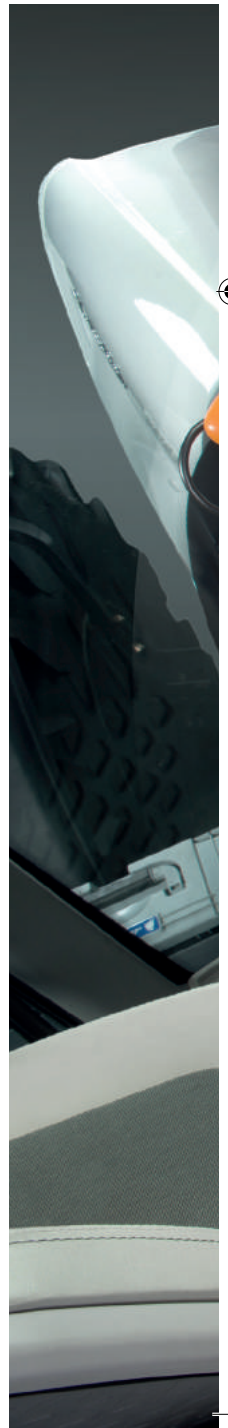

Front axle suspension

To drastically reduce vibration, the electronically controlled front axle suspension system keeps the suspension perfectly level irrespective of front load, making sure that the full shock absorber travel is usable in all conditions.





Ergonomic, functional controls

All control elements are grouped by functional area and by colour code and, in particular, those for engine control, driving, PTO and hydraulic functions are positioned on the armrest with the new ergonomic joystick. A 12.8" touchscreen monitor (iMonitor 2.0) and the Agrosky GPS guidance system are also available as options.

The soft LED control lighting also contributes to creating an even more comfortable ambience in the cab.





Air sprung cab suspension

This clever and innovative suspension system varies damping rate in real time. A dedicated sensor detects even the smallest changes in load within the cab, and feeds special pneumatic dampers with the amount of compressed air needed. This maintains constant suspension travel in all conditions, so that the full extension of the springs and dampers is always available.



Screen

A generously sized colour screen on the A-pillar displays all the information the driver needs clearly and intuitively.



ComforTip control

The ComforTip control lets the driver store and recall repetitive sequences, and automatically execute them by simply pushing the activation button on the joystick lever. To activate the system, simply press the enable button and activation button together.

When working, to automatically skip through the operations programmed in the sequence, simply press the activation button to move to the next operation.



**Xenon or LED lights**

With a choice of XENON or state of the art LED units, the work and driving lights of the Mach VRT contribute to its dynamic, determined looks. As well as the road lights, 9 rear work lights and 8 front work lights illuminate an extensive area surrounding the tractor to offer superb visibility for working at night.





Lights control panel
The controls for switching the lights on and off are activated using the Work Operating Light Panel (WOLP), which also lets the driver control the lights mounted on trailers or implements.



Easy access
The comfortable, padded passenger seat folds down to facilitate access to the cab.

**Steering wheel**

Steering wheel with soft-grip rim. The inclination of the instrument cluster adjusts together with steering wheel adjustment, for unparalleled visibility and driver comfort in all conditions.

Refrigerator and storage space for every necessity

A refrigerator and generously sized compartments let the driver store anything needed to make the working day more comfortable. Handy phone holder and cup holders also contribute to the comfort of the cab.

**Automatic A/C system**

The air conditioning and ventilation system maintains a comfortable, constant temperature inside the cab in all conditions: A generous supply of directional, adjustable flow vents placed ergonomically around the cab interior lets the driver quickly and easily set a comfortable cab temperature or quickly clear mist or frost from the windows and windscreen.



INNOVATION COMES FROM THE HEART.



The heart of the new Mach is the six cylinder DEUTZ TCD 6.1 LO6 4V Tier4i engine: a combination of technologies able to develop up to 263 Hp (194 kW) at 1,650 rpm, which remains almost constant between 1,650 rpm and 2,100 rpm. Four valves per cylinder, centrally positioned injectors, wastegate turbocharger and intercooler.

DCR (Deutz Common Rail) high pressure fuel injection system with integrated electronic control operating up to 2,000 bar, with exhaust gas treatment by means of an SCR catalytic converter. All features designed to ensure maximum performance, low fuel consumption and minimum emissions.

The efficient and reliable VRT transmission varies the transmission ratio continuously and automatically to take full advantage of the power of the engine effortlessly and without waste, making the driver's job even easier and more productive. Other features, such as the Load Sensing function, make the rear hitch simpler to control and more effective.

Boost Power

The new Deutz engines offer an additional 27 HP power boost when needed. This additional power is available when working with PTO powered implements and for road transport use.

PTO. 100% boost power available at speeds above 3 km/h.

TRANSPORT. 100% boost power available at speeds above 30 km/h.

4 work ranges

Four seamlessly selectable ranges ensure the right combination of ratios for every working operation. The result is the perfect ratio always, in a range of speeds from 0 to 50 Km/h (or 60 Km/h, where permitted by law), and unprecedented smoothness.

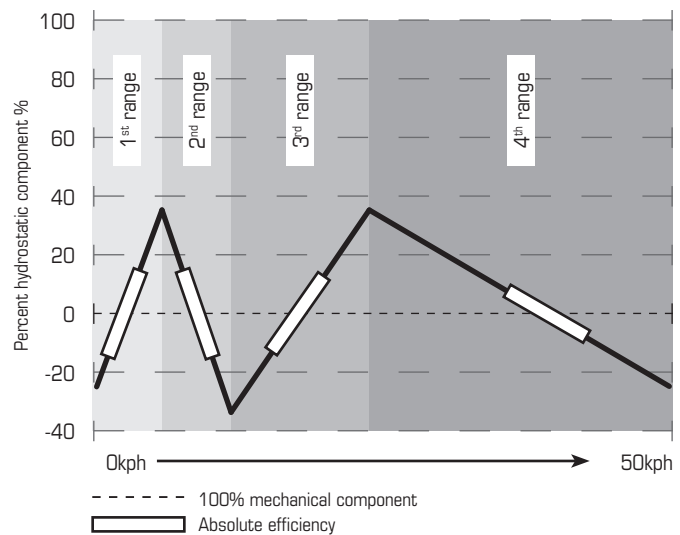



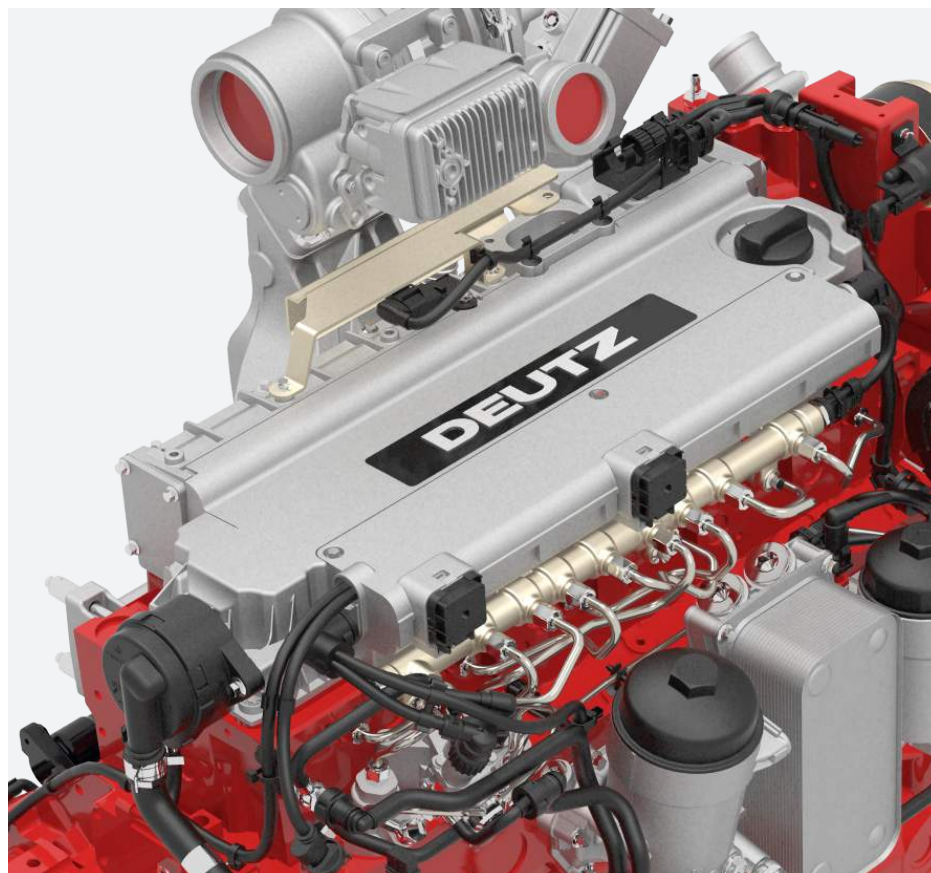

Common Rail

The high pressure common rail injection system, with two lubricated injection pumps integrated in the engine block, and the unique combustion chamber configuration, ensure superlative, constant performance even in the toughest jobs. The common rail injection system delivers injection pressures up to 2000 Bar irrespective of engine speed which, together with the electronic engine governor, ensures outstanding torque reserve even at very low engine speeds.

4 valves per cylinder
The four valve per cylinder head ensures efficient combustion chamber filling and optimised fuel-air mixture.

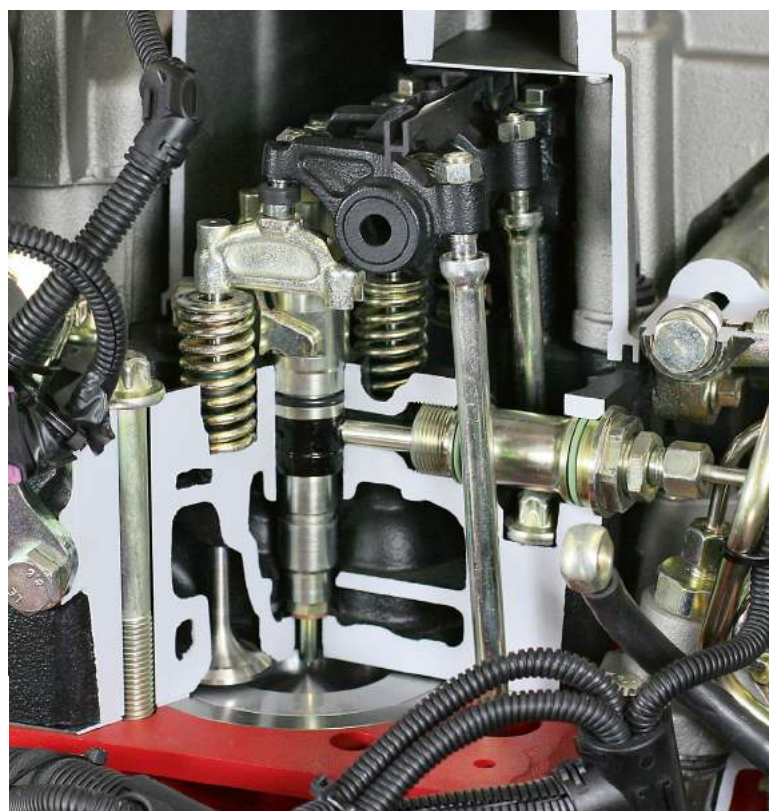



Shuttle

The shuttle control lever under the steering wheel lets the driver switch progressively between forward and reverse, even under load. A modulation wheel increases or decreases shuttle response. Direction changes may also be performed from practical controls on the multifunction lever with an interlock function to prevent accidental selection.



ASM

The electronic ASM systems engages and disengages dual traction and the differential locks in relation to speed and the steering angle of the front wheels to ensure maximum grip and traction (for ploughing and minimal tillage, for example) or maximum manoeuvrability and safety (for road transport).





EFFICIENCY FOR WORKING BETTER.

Superior versatility and the ability to adapt quickly to different working conditions are what make the Mach VRT such an unbeatable machine.

A rear PTO with four different speed modes (540/540E; 1000/1000E) makes the tractor truly capable of working with all implements in any situation. The user-friendly, versatile hydraulic system caters for even the most demanding applications.

The multiplate wet clutch is generously sized to absorb the load peaks involved when working with heavy duty implements, and engages progressively for superior reliability even when working with implements with high torque demands.



PTO Eco mode

This mode uses lower engine speeds to reduce fuel consumption and noise, and mid-range engine rpm delivers generous power and torque for maximum productivity.

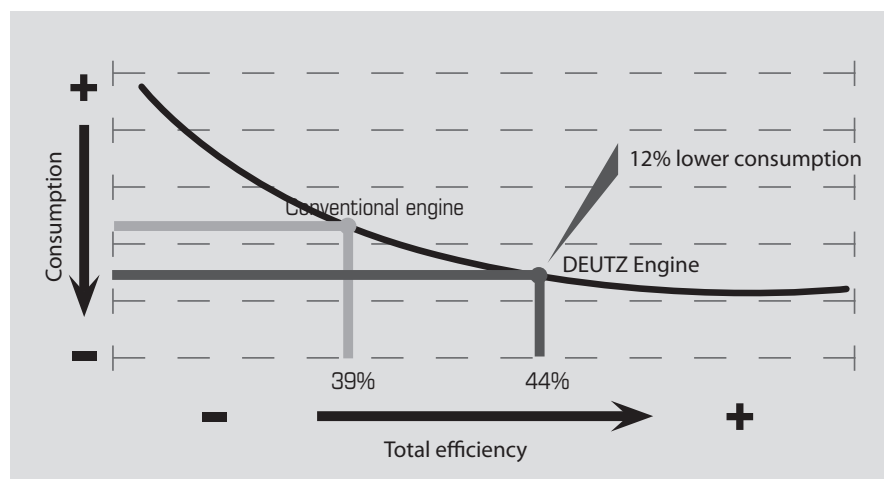
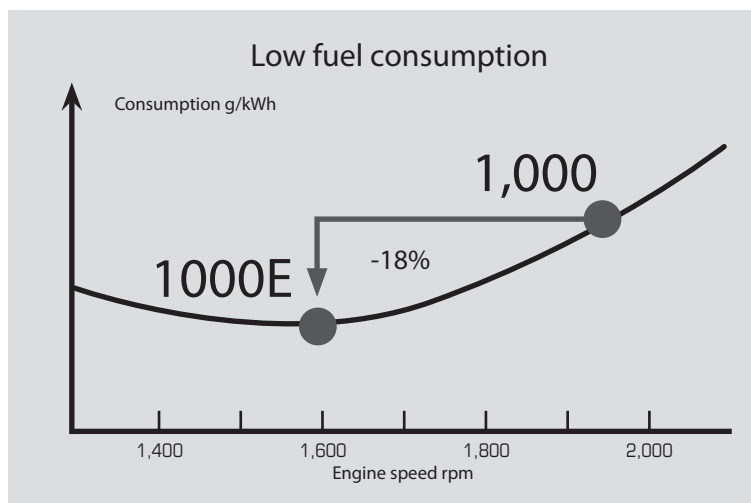
**SCR**

SCR (selective catalytic reduction of nitrogen oxides) technology is the most efficient method available today to attain compliance with Euro 4 emissions regulations. The SCR system used in Deutz engines reduces fuel consumption and maximises power by allowing the engine to operate with the optimum fuel/air mixture; only clean air is aspirated into the cylinder, not air contaminated with exhaust gases.

Optimised ratios

The ZF S Matic S240 transmission provides the Lamborghini Mach VRT with a maximum speed of 60 km/h at 2,100 rpm and 50 km/h at 1,750 rpm. Or, choosing the HD option, 50 km/h at 1,980 rpm and 40 km/h with the engine at 1,750 rpm. The driver can adjust the throttle setting in all driving modes by simply turning the dial on the multi-function joystick.

**Power Brake**

The Power Brake system maintains constant pressure in the hydraulic braking circuit so that the driver can rely on immediate response with powerful and progressive braking action at all times with minimum effort.

Manoeuvrability

The front axle and curved shape of the front hood panels offer a tight turning radius of just 5.8 m. The hydrostatic power steering with separate hydraulic circuit uses a 44 l/min pump and 2 double acting rams for a progressive, smooth steering action even at low engine speeds. The exclusive ASM system, which automatically engages and disengages 4-wheel drive and the differential locks, also contributes to manoeuvrability and traction.



Front PTO

For applications using both front and rear implements, the tractor is also available with an electrohydraulically controlled 1000 rpm front PTO driven directly by the engine via a multiplate wet clutch for progressive engagement.

Hydraulic system

The standard specification includes a separate 44 l/min power steering pump, in addition to the 120 l/min hitch and auxiliary valve pump or, as an option, 160 l/min pump. In addition, standard specification includes four double acting electronically controlled valves and Power-Beyond couplings with the valve options increased up to seven upon request,. Two of the seven valves direct oil to couplings at the front hitch. Lifting capacity is 10,000 Kg at the rear hitch and 4,500 Kg at the front.



Electronic hitch

All models are available with an efficient electronic hitch, which is monitored continuously by sensors and an integrated diagnostic system. This system offers a selection of different functions: draft and position control, quick soil engagement, mixed mode control, wheel slip control (with optional radar), implement lock for transport, lift height limiting, rate of drop control and ride control. The ride control function is activated automatically when driving on the road at speeds above 8 Km/h, and dampens implement oscillation and shock loading for maximum comfort and safety in all situations.

The hitch control functions are set within the armrest console, which displays the operating parameters on a digital screen mounted on the A-pillar.



Superior traction

The large rear tyres and heavy duty final drive units ensure maximum grip and effective traction, while the optimised weight distribution means less ballast is needed.







THAT A TRACTOR GOES THE EXTRA MILE.

On Mach VRT tractors, superior technology goes hand in hand with the advanced electronic system for the engine, transmission and brakes. The result is unparalleled performance and productivity in all conditions.

Electronically controlled turbo wastegate.

The wastegate of the turbocharger delivers higher boost pressures at lower engine speeds. Electronic boost pressure control ensures the ideal air-fuel ratio at low to mid engine speeds, while the system also monitors turbo pressure continuously, making it possible to respond immediately to changing loads.

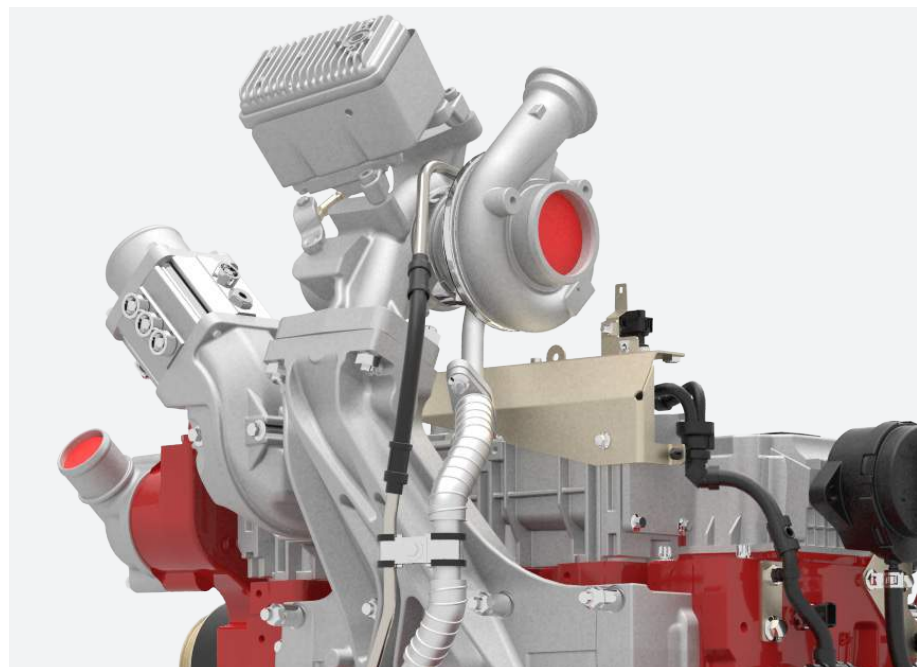



iMonitor 2.0

iMonitor is the multimedia interface for managing the main functions of Mach VRT tractors:

Main Menu, for controlling all machine functions (hitch, PTO, distributors, engine and transmission, ASM and cab suspension);
Performance Monitor (calculates consumption, productivity and land area worked);
ISO-Bus Monitor, for controlling compatible implements.

The system also lets the user download performance data for maintaining productivity records.



Electronic engine throttle

The innovative electronic engine throttle system analyses the information and parameters received from the engine, from sensors and from the driver, to deliver power when required quickly and effectively. With maximum power available over a broad rev band, as increased load causes a dip in engine speed, torque increases and power remains constant, significantly reducing specific fuel consumption. In tractive applications such as ploughing and heavy transport, these characteristics translate to superior tractive force and flexibility, for even greater productivity.





AUTO PTO

The Auto PTO mode lets the driver programme when to disengage and reactivate the PTO in relation to the vertical position of the rear hitch.



EPB

The innovative Electronic Park Brake systems holds the tractor safely and effectively. The EPB engages automatically if the tractor is stationary for more than 30 seconds or if the driver leaves the driver seat.





External PTO control

For greater practicality and safety, the PTO may be operated either from the driver seat or from controls on the rear mudguards.



Dynamic braking control

When the driver brakes without depressing the clutch pedal, the transmission automatically adjusts the drive ratio to prevent acceleration and assist braking to maintain the correct speed. This control function is activated in conjunction with pressing the activation button on the armrest console which will reduce brake heating and wear, and is particularly useful when working with implements such as large balers, slurry tankers or trailers used on hilly terrain.

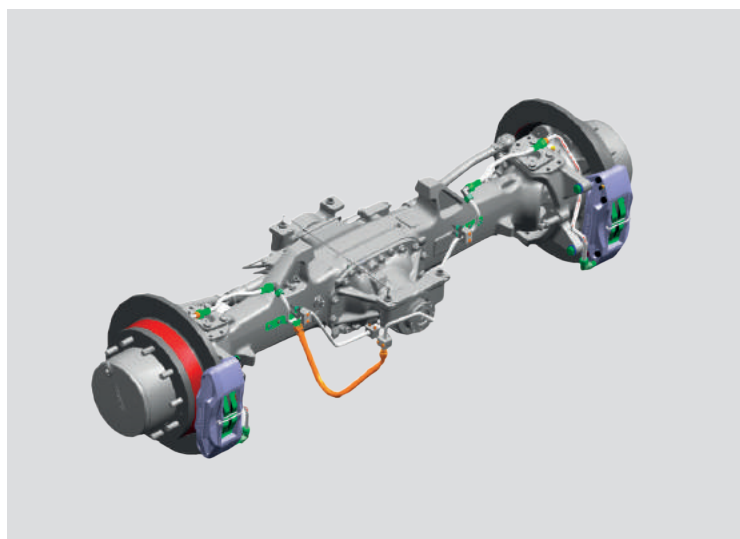

Integral four-wheel braking

The large diameter multi-disc rear brakes operate both sides of the rear differential output shaft. The optional inboard front dry disc brakes which are fitted on 60 km/h models are particularly effective when transporting on gradients, where the additional braking capacity is a major advantage.

VRT transmission

The electronically controlled VRT transmission offers three different modes - Manual, PTO and Automatic - to cater for every possible application.

Manual Mode

Ideal for applications where constant engine speed is needed. The tractor drives and behaves like a tractor with a conventional transmission. The driver uses the accelerator pedal and/or the multifunction joystick to obtain the ideal balance between engine speed and ground speed.

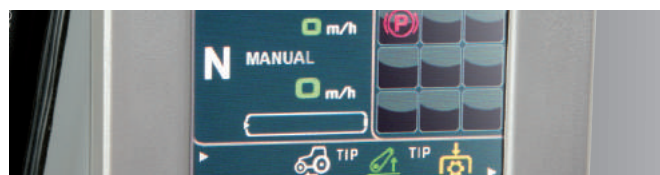

MANUAL

PTO Mode:

This mode is selected automatically when the PTO is engaged. In this mode, the speed set by the driver with the hand throttle is maintained at a constant value while working, independently of tractor speed.



PTO

Automatic Mode

Ideal for transport or for field applications which do not need a constant engine speed, such as ploughing and minimal tillage.

The electronic system adjusts engine speed within an optimum range in relation to load conditions, while maintaining a constant ground speed.

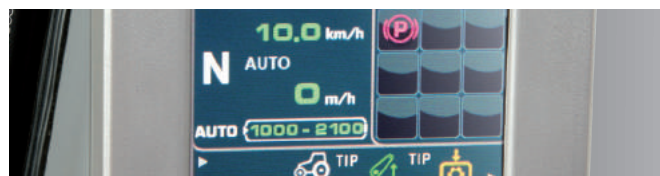

AUTOMATIC

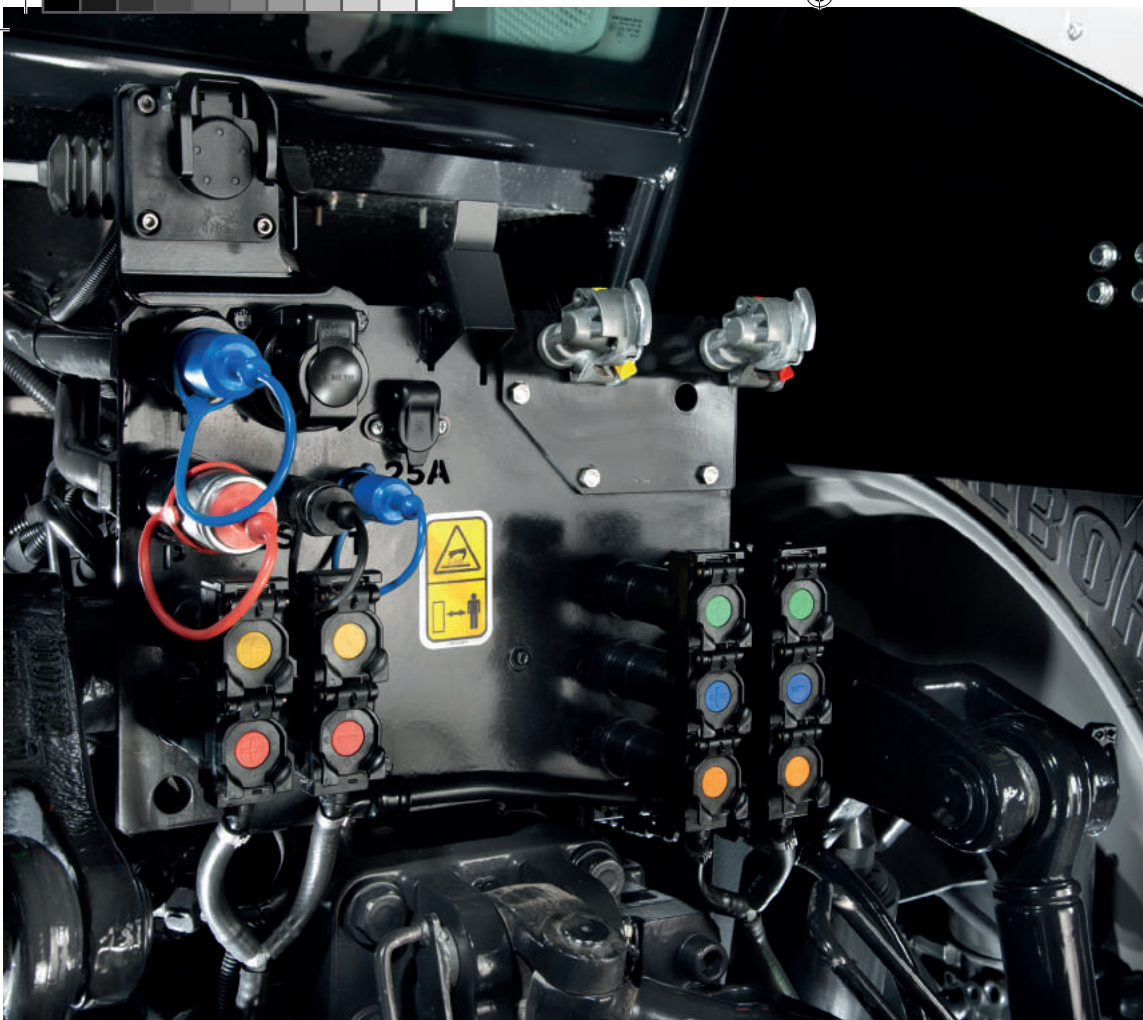

Auxiliary valves

The hydraulic system offers up to 7 auxiliary valves (5 rear + 2 front). The flow regulation and oil delivery time control functions are set from buttons on the armrest console.

Separate tank

The hydraulic oil tank feeding oil to the hitch and auxiliary valves is completely separate from the transmission circuit and has its own filtration system.

Hydraulic couplings

Push-pull hydraulic couplings are used, allowing hydraulic lines to be coupled even if the system is pressurised. An oil spill container collects any oil which may escape when coupling the hydraulic lines of the implement.

Power Zero function

The Power Zero function brakes the wheels without using the brake pedal, and lets the driver set off again using only the accelerator pedal. The function also holds the tractor in a stationary position irrespective of gradient and load without having to apply the parking brake.



Cruise control

In Auto and PTO modes, the driver can set and store two forward and two reverse cruise speeds, which are memorised and stored even after switching the tractor off. The cruise speed setting may also be adjusted while the function is engaged. All speed settings are highlighted on the large display on the cab A-pillar or directly on the iMonitor 2.0



TECHNICAL DATA

MACH VRT T4i

		210 VRT	230 VRT	250 VRT
ENGINE				
Manufacturer		Deutz	Deutz	Deutz
Model		TCD 6.1 L06	TCD 6.1 L06	TCD 6.1 L06
Emissions		Tier 4i	Tier 4i	Tier 4i
Cylinders/Capacity	No./cc	6/6057	6/6057	6/6057
Turbo intercooler		●	●	●
Viscostatic fan		●	●	●
Deutz Common Rail (DCR)	bar	1,600	1,600	2,000
Max. power (ECE R120)	kW/HP	151/205	162/220	175/238
Max. power with boost (ECE R120)	kW/HP	165/224	180/245	194/263
Power at rated engine speed, with boost (ECE R 120)	kW/HP	163/222	178/242	190/258
Power at rated engine speed (ECE R 120)	kW/HP	137/186	150/204	174/236
Max. homologated power at rated speed (2000/25/EC)	kW/HP	163/222	178/242	190/258
Engine speed at maximum power	rpm	1,900	1,900	1,900
Max. engine speed (rated)	rpm	2,100	2,100	2,100
Max. torque with boost	Nm	883	937	1009
Maximum torque	Nm	806	870	934
Engine speed at maximum torque	rpm	1,600	1,600	1,600
Torque rise		20%	16%	17%
Electronic engine governor		●	●	●
Air filter with dust ejector		●	●	●
Exhaust on cab A-pillar		●	●	●
Fuel tank capacity	litres	435	435	435
AdBlue® tank capacity	litres	50	50	50
Biodiesel fuel (EN 14214)		B100	B100	B100
CONTINUOUSLY VARIABLE TRANSMISSION				
Model		ZF S-Matic S180+	ZF S-Matic S240/S240HD	ZF S-Matic S240/S240HD
Number of speed ranges	No.	4	4	4
Max. speed	km/h	40/50	40/50/60	40/50/60
Overspeed (40 Km/h Eco)		●	●	●
Overspeed (40 Km/h SuperEco)		●	● / -	● / -
Overspeed (50 Km/h Eco)		●	● / -	● / -
PowerZero		●	●	●
CruiseSpeed	No.	2+2	2+2	2+2
Driving Strategies (Auto/Manual/PTO)		●	●	●
Eco/Power control		●	●	●
Hydraulic reverse power shuttle		●	●	●
SenseClutch		●	●	●
PTO				
540ECO/1000/1000ECO PTO		-	●	●
540/540ECO/1,000/1,000ECO PTO		●	-	-
1000 front PTO		●	●	●
1000ECO front PTO		○	○	○
AXLES AND BRAKES				
Suspended front axle		●	●	●
Four wheel drive electrohydraulically engaged		●	●	●
Electrohydraulically operated differential lock		●	●	●
ASM system		●	●	●
Four wheel braking		●	●	●
External disc brakes		○	○	○
PowerBrake		●	●	●
Automatic electronic parking brake (EPB)		●	●	●
ELECTRICAL SYSTEM				
Voltage		12V	12V	12V
Standard battery	V/Ah/A	12/180/700	12/180/700	12/180/700
Alternator	V/A	12/200	12/200	12/200
Starter motor	V/kW	12/4	12/4	12/4
External power socket		●	●	●
Power socket for higher current applications		●	●	●

TECHNICAL DATA		MACH VRT T4i		
		210 VRT	230 VRT	250 VRT
HYDRAULIC SYSTEM AND HITCH				
Pump delivery (std)	l/min	120	120	120
Closed centre hydraulic system (Load Sensing)		●	●	●
Pump delivery (opt)	l/min	160	160	160
Max. usable oil volume	litres	45	45	45
Separate ancillary oil tank		●	●	●
Auxiliary hydraulic valves (std)	No. of	4	4	4
Auxiliary hydraulic valves (opt)	n° of valves	5/6/7	5/6/7	5/6/7
Rear hitch electronic		●	●	●
Rear electronic lift capacity (std/opt)	Kg	10000	10000	10000
Front hitch		○	○	○
Front lifting capacity	Kg	4500	4500	4500
CAB				
Maxi Vision Cab		●	●	●
Mechanical suspension		●	●	●
Air suspension		○	○	○
Adjustable rear view mirrors		○	○	○
Heated adjustable rear view mirrors		○	○	○
Air conditioning		●	●	●
Automatic A/C system		○	○	○
High visibility roof		●	●	●
MaxiCom multifunction armrest		●	●	●
Multifunction joystick		●	●	●
Work Display		●	●	●
Light control panel		●	●	●
iMonitor ²		○	○	○
Agrosky system		○	○	○
ISO-Bus compatible		○	○	○
Comfortip Professional		○	○	○
Max Comfort Dynamic Seat XL ++ (dynamic low frequency suspension)		●	●	●
Max Comfort Dynamic Seat XXL ++ (dynamic suspension, low frequency)		○	○	○
Max Comfort Dynamic Seat EVO Active + (active dynamic suspension,		○	○	○
Padded passenger seat		●	●	●
Wiring for audio system with speakers		●	●	●
Halogen work lights		●	●	●
LED work lights		○	○	○
Xenon work lights		○	○	○
HOOKS				
Automatic tow hook		○	○	○
Height adjustable ball head joint		○	○	○
Fixed ball head joint		○	○	○
Oscillating arm		○	○	○
Pickup hitch		○	○	○
Piton Fix		○	○	○
DIMENSIONS AND WEIGHTS				
With front tyres		600/70R30	600/70R30	600/70R30
With rear tyres		650/65R42	650/65R42	650/65R42
Wheelbase	mm	2817	2817	2817
Length	mm	4817-4972	4817-4972	4817-4972
Height	mm	3103-3153	3103-3153	3103-3153
Width	mm	2500-2736	2500-2736	2500-2736
Ground clearance	mm	555-685	555-685	555-685
Front unladen weight	kg	3000-3795	3100-3915	3100-3915
Rear unladen weight	kg	4700-4785	5100-5185	5100-5185
Total unladen weight	kg	7700-8580	8200-9100	8200-9100
Max. permissible front weight	kg	5,200	5,200	5,200
Max. permissible rear weight	kg	9,000	10,000	10,000

STD ● OPT ○



DEALER

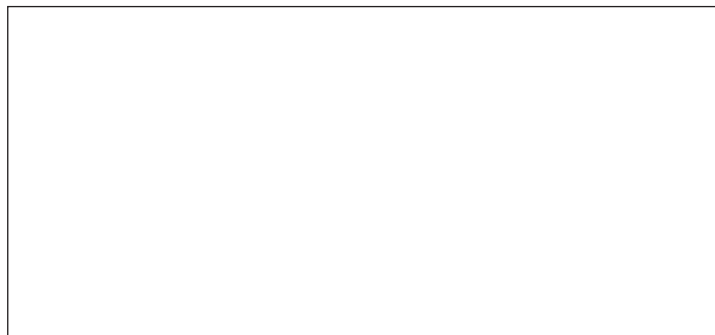

Produced by Marketing/Communication Department - Code 308.8514.3.2-1 - 6/14 I.P.

Lamborghini trattori recommends the use of original SDF lubricants and coolants



LAMBORGHINI TRATTORI is a brand of  SAME DEUTZ-FAHR
lamborghini-tractors.com

